

RANGE H**NF X 15-211 class 2**

DUCTLESS FUME HOODS Labopur®

NF X 15-211 - MAI 2009 - CLASS 2

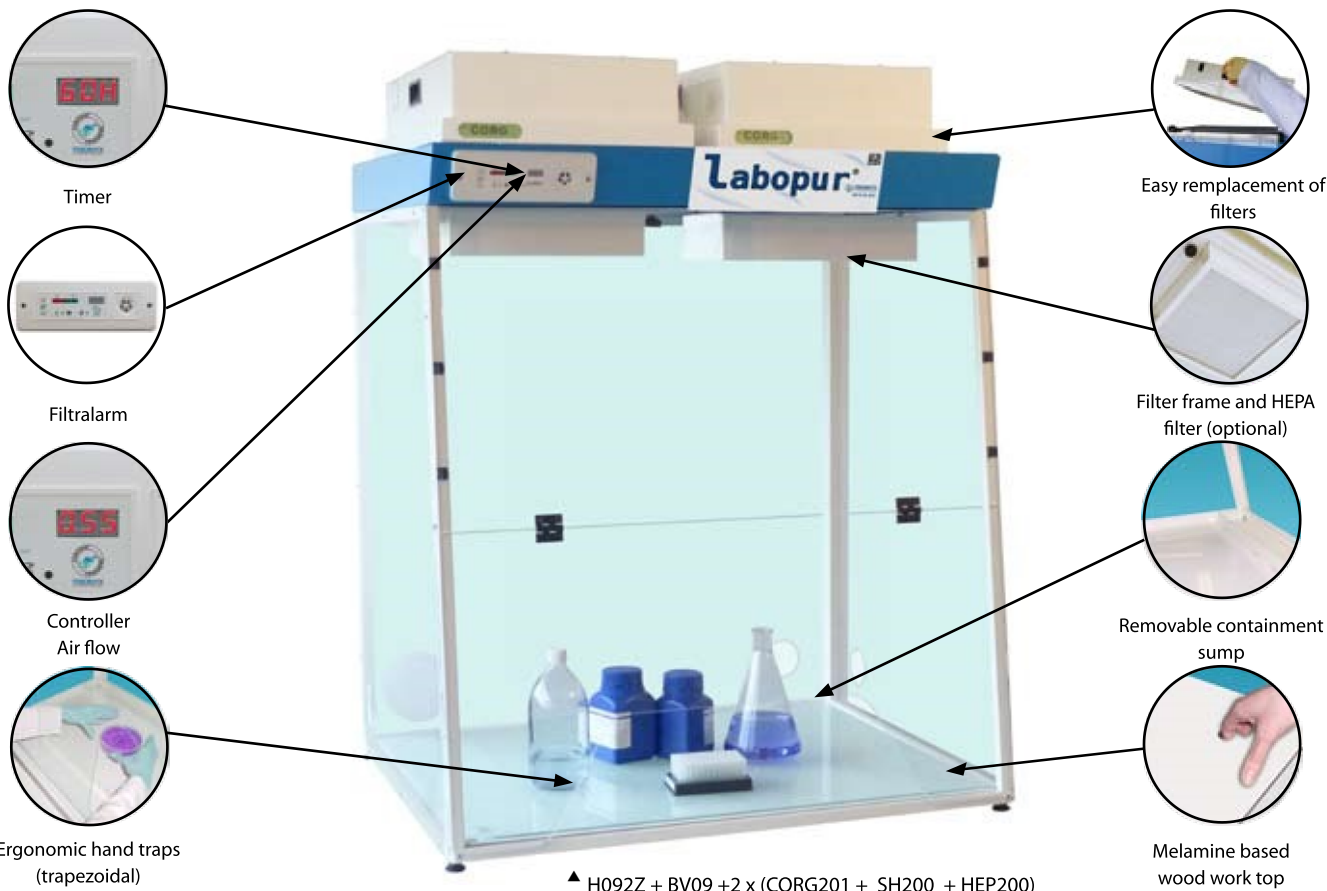

▲ H092Z + BV09 + 2 x (CORG201 + SH200 + HEP200)

ADVANTAGES

User's optimal protection:

- Our fume hoods have been approved within the standard NF X 5-211 by an independent laboratory.
- Vapors are confined in the manipulation enclosure after being eliminated through the molecular filter.
- A front sampling outlet allows you a fast and reliable control of the filter saturation.
- A warning lamp located in facade informs you of the good functioning of the system of ventilation/filtration.
- Silent electric fan according to E.U specifications.
- A front control window indicates immediately if the filter is in place and well adapted to your work.

Save time and energy :

- Our hoods are delivered ready to use (already mounted). All you have to do is to plug them to a power supply device.
- No connecting evacuation, no civil engineering needed (if the hood is fitted with a filter).
- It is not necessary to heat or cool the air within the workroom.

Confort of use:

- The transparent wall sides of the fume hood offer an optimal lighting of the work-top and a direct sight of the working products.
- The ergonomic hand traps or trapezoidal opening allow secure and easy manipulations in the enclosure.
- Protective caps allow you to insert the power cables of your devices into the fume hoods.
- Silent fan allows you to focus on your work.
- Easy replacement of the active coal-based filter in a short time.

TECHNICAL DATA

- 15/10th steel construction.
- White epoxy painting RAL 9010 and Blue 5015, with high resistance against chemicals.
- PMMA glazed walls.
- Average air speed at the front: 0.5 m / s
- Voltage: 220-240 volts
- Electrical power: 10 W
- Intensity: 0.1 A
- Sound level of fan (excluding airflow): 57 dB (A)
- Flow rate: 170 m³ / h

STANDARD EQUIPMENT:

- 4 covers for feed and fluid going through
- Air Flow Controller
- Timer
- Sampling outlet
- Transparent rear wall

OPTIONAL EQUIPMENT:

- Manual pump to determine saturation of filters: PMAF
- Reactive Tubes
 - TROR: Pack of 10 «organic» reactive tubes
 - TRAC: Pack of 10 «corrosive» reactive tubes
 - TROA: Set of 5 «organic» and 5 corrosive reactive tubes
- A retention tank integrated under the work-top allows to get back liquids in case of accidental droppings.

Flammable cabinets

Corrosive cabinets

Toxic cabinets and multirisk

Pesticide range

Fume hoods, filtering cabinets - Ventilation

Containment and Cans

Anti-fire equipments and File cabinets

Showers and first-aid equipments



ACTIVE CHARCOAL FILTERS AND HEPA H14 FILTER

ACTIVE CHARCOAL FILTERS



▲ ORG200

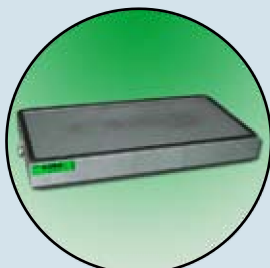

▲ CORG201

Activated carbon is an extremely porous black carbon allowing the adsorption of molecules from chemicals thanks to the high degree of microporosity (less than 2 µm).

Based on the chemicals you have to filter, activated carbon can be impregnated to improve the adsorption capacity. A specific impregnation could fit for one product and be unadapted for another one.

Our filters are made with the best active charcoal. In order to offer the best guarantees, the quality of filters adsorption was tested and approved by an independent laboratory. Every active charcoal filter is provided with a double anti-dust filter to insure an optimal filtration quality. Your health is protected. We offer 4 types of filters: one dedicated to organic vapors, one «Universal» for corrosive and organic vapors, one for formaldehyde vapors and one for ammonia vapors.

We offer 4 standard filters :

- typ ORG for organic vapors,
- typ CORG for corrosive and organic vapors
- typ FOR for formaldehyde vapors
- typ AMM for ammonia vapors

CORG filter adsorb a large majority of commonly used chemicals : organic and inorganic acids, solvents and organics. This filter can be used in most of the cases.

We also offer **specialized impregnated filters**, for exemple, for manipulation of specific chemicals. If you need further information please do not hesitate to contact-us.

HEPA H14 FILTER AND HEPA FILTER FRAME



▲ SH200 + HEP200

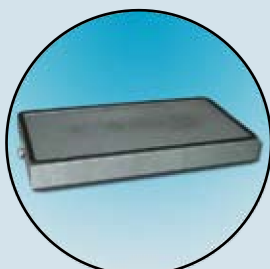

▲ CAR200

Hepa filter (High Efficiency Particulate Air) is an air filter with a very high efficiency.

The Hepa filtration efficiency is controlled and approved according to the norm NF EN 1822 and divided into 5 efficiency classes. The H14 Hepa filter which is the most efficient will stop 99,97% of the particles with a diameter equal or bigger than 0,3 µm.

When handling chemical powders, you have to use a standard particulate filter called HEPA. To guarantee the highest filtration efficiency, we choose a HEPA filter type H14 approved to the EN 1822 standards. In order to receive a HEPA filter, your ductless fume hood must be fitted with a dedicated frame type SH.

Your powders filter may need to be complemented by an additional active coal filter to provide you the best security and efficiency.

If you want to use your ductless fume hood for powders only, a specific kit should be taken. For further information, please refer to the paragraph «Kit for using ductless fume hood without active charcoal filter».

N.B. : We deliver ductless fume hood only with either an activated carbon filter or a connecting kit for use without activated carbon filter (CAR).

The manufacturer reserves the right to discontinue or change specifications or designs at any time without notice and without incurring obligations. 03/2017

Flammable cabinets

Corrosive cabinets

Toxic cabinets and multirisk

Pesticide range

Fume hoods, filtering cabinets - Ventilation

Containment and Cans

Anti-fire equipments and File cabinets

Showers and first-aid equipments

RANGE H**NF X 15-211 class 2****STANDARD EQUIPMENTS****FILTRALARM**

Available as a standard feature on all Labopur Fumehoods with ventilation / filtration system, the filtralarm allows to measure the airflow in the filter thanks to an electronic chip, to detect and warn you of clogging of the filter or any anomaly of the airflow by a visual and audio signal. Furthermore, this controller's new generation can also display the hour counter.

**AIR VELOMETER**

According to the French standard NF X 15-211, your hood is supplied with an air velometer. It allows you to check permanently the velocity of the air in facade and verify that the fume hood works in depression guaranteeing the flow of vapors through the filter.

**PROTECTIVE CAPS**

All of our fume hoods are equipped with protective caps allowing to easily insert power cable supplies or gas for instance.

**TIMER**

The standard timer supplied with your hood indicates you, all the time, the total use duration of your hood. After programming, every 60 hours, a sound alarm invites you to check the saturation of the active coal filter.

**TRANSPARENT WALLS**

Our fume hoods are delivered with transparent walls on every face offering you a clear working area.

**SAMPLING OUTLET**

A front sampling outlet gives you the opportunity to check quickly and in a reliable way the saturation level of your active charcoal filter, thanks to the manual pump and reactive tubes.

**ADSORBED PRODUCTS BOOKLET**

Following the standard NF X 15-211, your hood is delivered with a CD-Rom information guide regarding the adsorption capacity of the active coal filter in relation with various chemicals.

OPTIONAL EQUIPMENTS**MELAMINE BASED WOOD WORK-TOP**

Manufactured in melamine based wood, it offers an excellent resistance to chemicals attacks.

**RETENTION TANK**

A retention tank is placed under each work-top being part of the fume hood. In case of leak or of accidental reversal, treated liquids are retained. To clean it, you just need to lift the work-top and use an «absorbent».

**TEMPERED GLASS WORK TOP.**

Willing to treat extremely aggressive products? Choose a tempered glass work-top instead of a H.P.L. top (in standard within the LABOPUR hoods).

**MANUAL PUMP AND REACTIVE TUBES**

TAKE CARE OF YOUR HEALTH! Check your active coal filter saturation thanks to the manual pump and reactive tubes. We offer you a wide range of reactive tubes depending on your products used.

**ACTIVE COAL FILTERS AND HEPA H14 FILTERS**

The fume hoods are delivered without active coal filters and/or HEPA H14 filters. You must select one depending on your chemicals used. Consult our active coal filters selection guide.

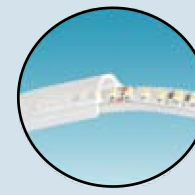
**LIGHTING**

We offer you a LED which is integrated into the enclosure while being outside the handling zone. IP65 - 10W - 4200K

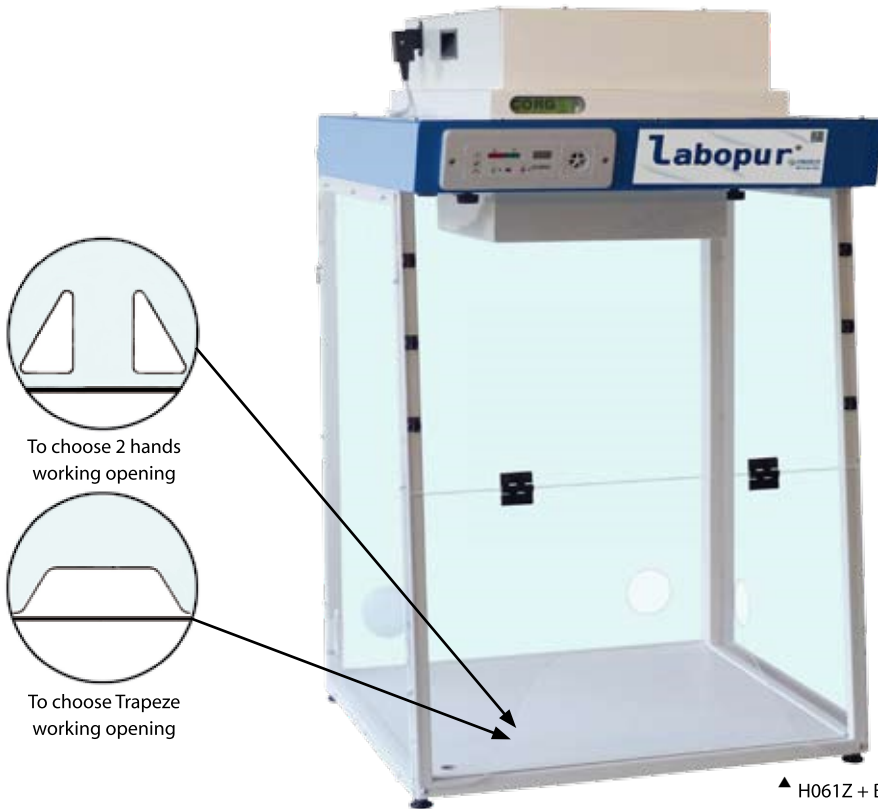
RANGE H**NF** X 15-211 class 2**Labopur® 600 mm**

To choose 2 hands working opening

To choose Trapeze working opening

▲ H061Z + BB06 + CORG201 + SH200 + HEP200

Fume Hood without bottom to equip, see accessories	H06	
External dimensions (H x W x D in mm)	950 x 600 x 650	
Internal dimensions (H x W x D in mm)	735 x 545 x 505	
Weight (kg)	23	
Number of filter module / Fan	1	
Working opening type	2 hands	Trapeze
Référence	H061D	H061Z
For chemical use only		
Activated carbon filter for organic vapors	ORG200 (11 kg)	
Activated carbon filter for corrosive and organic vapors	CORG201 (12 kg)	
Activated carbon filter for formaldehyde vapors	FOR200 (12 kg)	
Activated carbon filter for ammonia vapors	AMM 200 (12 kg)	
For powder use only		
H14 Hepa filter	HEP200 (2 kg)	
Hepa filter holder	SH200 (4 kg)	
Ventilation element(s) (required for use of powders only)	CAR200 (2 kg)	
For powder and chemical use		
H14 Hepa filter for powder handling	HEP200 (2 kg)	
Hepa filter holder	SH200 (4 kg)	
Activated carbon filter for organic vapors	ORG200 (11 kg)	
Activated carbon filter for corrosive and organic vapors	CORG201 (12 kg)	
Activated carbon filter for formaldehyde vapors	FOR200 (12 kg)	
Activated carbon filter for ammonia vapors	AMM200 (12 kg)	
Additional accessories		
Containment sump + HPL work top	BB06 (10 kg)	
Containment sump + Tempered glass work top	BV06 (15 kg)	
Integrated outdoor light	LUMI (1 kg)	
Tubular table on 4 feet	TTF06 (9 kg)	
Tubular roller table (on castors)	TTR06 (10 kg)	
Monobloc rolling table with storage shelf	TR06 (28 kg)	
Table / trolley cabinet	TA06 (32 kg)	

The manufacturer reserves the right to discontinue or change specifications or designs at any time without notice and without incurring obligations. 09/2017

Flammable cabinets

Corrosive cabinets

Toxic cabinets and multirisk

Pesticide range

Fume hoods, filtering cabinets - Ventilation

Containment and Cans

Anti-fire equipments and File cabinets

Showers and first-aid equipments

RANGE H**NF** X 15-211 class 2

Labopur® 900 mm

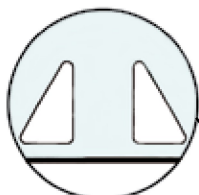

To choose 2 hands
working opening

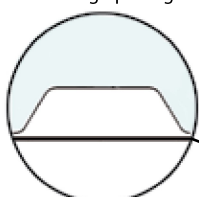

To choose Trapeze
working opening

▲ H092Z + BB09 + 2 x (CORG201 + SH200 + HEP200)

Fume Hood without bottom to equip, see accessories	H09		
External dimensions (H x W x D in mm)	1160 x 900 x 750		
Internal dimensions (H x W x D in mm)	935 x 845 x 700		
Weight (kg)	34		
Number of filter module / fan	1	2	
Working opening type	2 hands	2 hands	Trapeze
Référence	H091D	H092D	H092Z
For chemical use only			
Activated carbon filter(s) for organic vapors	ORG200 (11 kg)	2 x ORG200 (22 kg)	
Activated carbon filter(s) for corrosive and organic vapors	CORG201 (12 kg)	2 x CORG201 (24 kg)	
Activated carbon filter(s) for formaldehyde vapors	FOR200 (12 kg)	2 x FOR200 (24 kg)	
Activated carbon filter(s) for ammonia vapors	AMM 200 (12 kg)	2 x AMM200 (24 kg)	
For powder use only			
H14 Hepa filter(s)	HEP200 (2 kg)	2 x HEP200 (4 kg)	
Hepa filter holder	SH200 (4 kg)	2 x SH200 (8 kg)	
Ventilation element(s) (required for use of powder only)	CAR200 (2 kg)	2 x CAR200 (4 kg)	
For powder and chemical use			
H14 Hepa filter(s) for powder handling	HEP200 (2 kg)	2 x HEP200 (4 kg)	
Hepa filter holder	SH200 (4 kg)	2 x SH200 (8 kg)	
Activated carbon filter(s) for organic vapors	ORG200 (11 kg)	2 x ORG200 (22 kg)	
Activated carbon filter(s) for corrosive and organic vapors	CORG201 (12 kg)	2 x CORG201 (24 kg)	
Activated carbon filter(s) for formaldehyde vapors	FOR200 (12 kg)	2 x FOR200 (24 kg)	
Activated carbon filter(s) for ammonia vapors	AMM200 (12 kg)	2 x AMM200 (24 kg)	
Additional accessories			
Containment sump + HPL work top	BB09 (11 kg)		
Containment sump + Tempered glass work top	BV09 (16 kg)		
Integrated outdoor light	LUMI (1 kg)		
Tubular table on 4 feet	TTF09 (12 kg)		
Tubular roller table (on castors)	TTR09 (13 kg)		
Monobloc rolling table with storage shelf	TR09 (37 kg)		
Table / trolley cabinet	TA09 (43 kg)		

The manufacturer reserves the right to discontinue or change specifications or designs at any time without notice and without incurring obligations. 09/2017

Flammable
cabientsCorrosive
cabientsToxic cabients
and multiriskPesticide
rangeFume hoods, filtering
cabients - VentilationContainment
and CansAnti-fire equipments
and File cabientsShowers and first-
aid equipments

RANGE H**NF** X 15-211 class 2

Labopur® 1200 mm

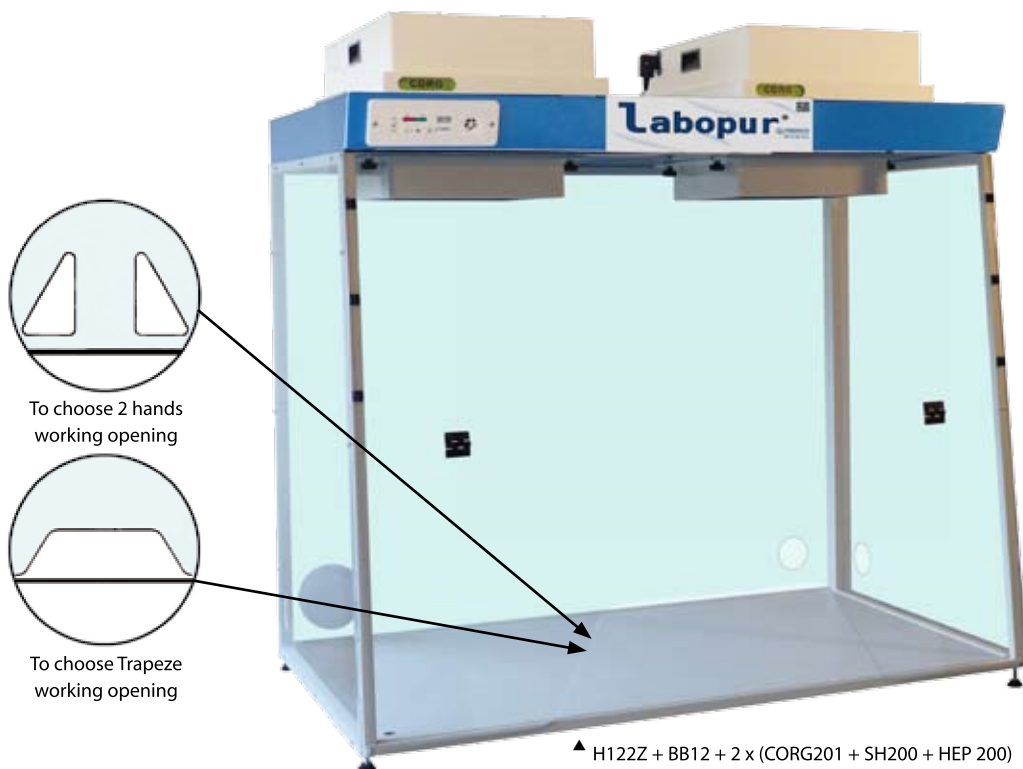

▲ H122Z + BB12 + 2 x (CORG201 + SH200 + HEP 200)

Fume Hood without bottom to equip, see accessories	H12		
External dimensions (H x W x D in mm)	1160 x 1200 x 750		
Internal dimensions (H x W x D in mm)	935 x 1145 x 700		
Weight (kg)	44		
Number of filter module / Fan	1	2	
Working opening type	2 hands	2 hands	Trapeze
Référence	H121D	H122D	H122Z
For chemical use only			
Activated carbon filter(s) for organic vapors	ORG200 (11 kg)	2 x ORG200 (22 kg)	
Activated carbon filter(s) for corrosive and organic vapors	CORG201 (12 kg)	2 x CORG201 (24 kg)	
Activated carbon filter(s) for formaldehyde vapors	FOR200 (12 kg)	2 x FOR200 (24 kg)	
Activated carbon filter(s) for ammonia vapors	AMM 200 (12 kg)	2 x AMM200 (24 kg)	
For powder use only			
H14 Hepa filter(s)	HEP200 (2 kg)	2 x HEP200 (4 kg)	
Hepa filter holder	SH200 (4 kg)	2 x SH200 (8 kg)	
Ventilation element(s) (required for use of powder only)	CAR200 (2 kg)	2 x CAR200 (4 kg)	
For powder and chemical use			
H14 Hepa filter(s) for powder handling	HEP200 (2 kg)	2 x HEP200 (4 kg)	
Hepa filter holder	SH200 (4 kg)	2 x SH200 (8 kg)	
Activated carbon filter(s) for organic vapors	ORG200 (11 kg)	2 x ORG200 (22 kg)	
Activated carbon filter(s) for corrosive and organic vapors	CORG201 (12 kg)	2 x CORG201 (24 kg)	
Activated carbon filter(s) for formaldehyde vapors	FOR200 (12 kg)	2 x FOR200 (24 kg)	
Activated carbon filter(s) for ammonia vapors	AMM200 (12 kg)	2 x AMM200 (24 kg)	
Additional accessories			
Containment sump + HPL work top	BB12 (12 kg)		
Containment sump + Tempered glass work top	BV12 (17 kg)		
Integrated outdoor light	LUMI (1 kg)		
Tubular table on 4 feet	TTF12 (22 kg)		
Tubular roller table (on castors)	TTR12 (23 kg)		
Monobloc rolling table with storage shelf	TR12 (51 kg)		
Table / trolley cabinet	TA12 (54 kg)		

The manufacturer reserves the right to discontinue or change specifications or designs at any time without notice and without incurring obligations. 09/2017

Flammable cabinets

Corrosive cabinets

Toxic cabinets and multirisk

Pesticide range

Fume hoods, filtering cabinets - Ventilation

Containment and Cans

Anti-fire equipments and File cabinets

Showers and first-aid equipments

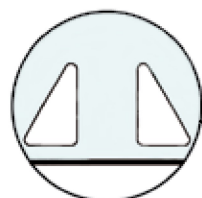
RANGE H**NF X 15-211 classe 2****Labopur® 1500 mm**

To choose 2 hands working opening

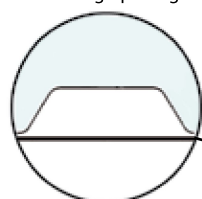

To choose Trapeze working opening

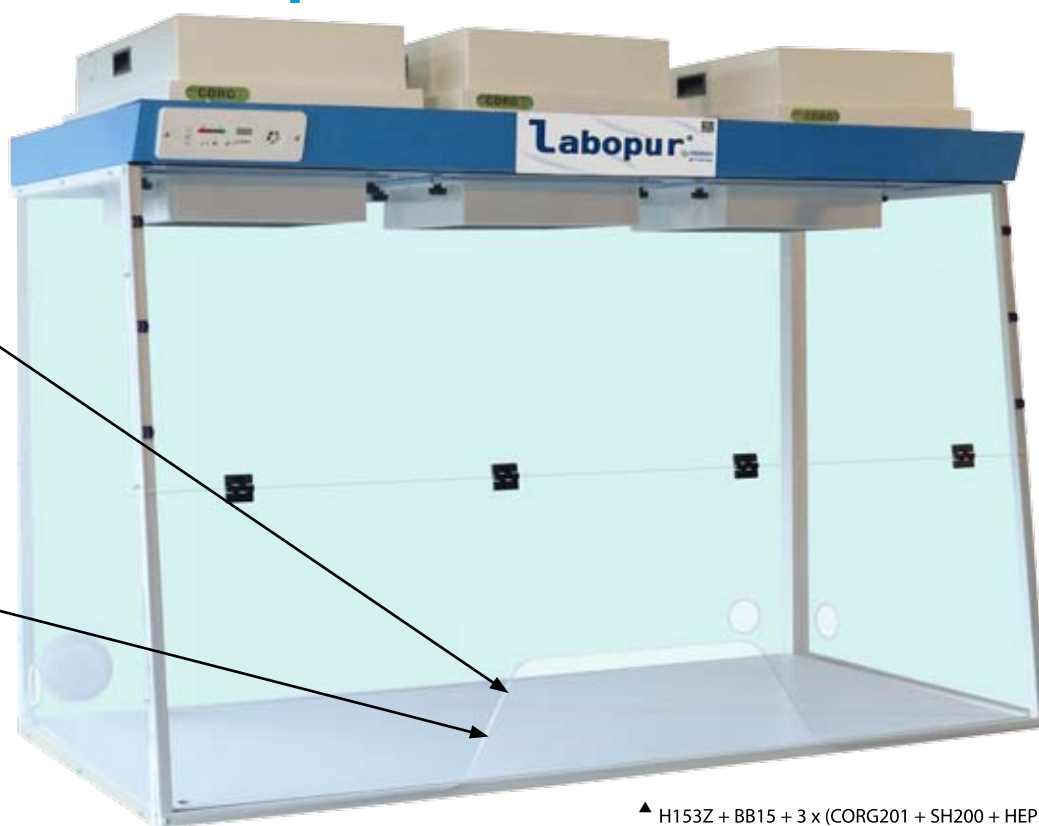

▲ H153Z + BB15 + 3 x (CORG201 + SH200 + HEP200)

Fume Hood without bottom to equip, see accessories	H15				
External dimensions (H x W x D in mm)	1160 x 1500 x 750				
Internal dimensions (H x W x D in mm)	935 x 1445 x 700				
Weight (kg)	54				
Number of filter module / Fan	2		3		
Working opening type	2 hands	Trapeze	2 hands	Trapeze	Large width
Reference	H152D	H152Z	H153D	H153Z	H153G
For chemical use only					
Activated carbon filter(s) for organic vapors	2 x ORG200 (22 kg)		3 x ORG200 (33 kg)		
Activated carbon filter(s) for corrosive and organic vapors	2 x CORG201 (24 kg)		3 x CORG201 (36 kg)		
Activated carbon filter(s) for formaldehyde vapors	2 x FOR200 (24 kg)		3 x FOR200 (36 kg)		
Activated carbon filter(s) for ammonia vapors	2 x AMM200 (24 kg)		3 x AMM200 (36 kg)		
For powder use only					
H14 Hepa filter(s)	2 x HEP200 (4 kg)		3 x HEP200 (6 kg)		
Hepa filter holder	2 x SH200 (8 kg)		3 x SH200 (12 kg)		
Ventilation element(s) (required for use of powder only)	2 x CAR200 (4 kg)		3 x CAR200 (6 kg)		
For powder and chemical use					
H14 Hepa filter(s) for powder handling	2 x HEP200 (4 kg)		3 x HEP200 (6 kg)		
Hepa filter holder	2 x SH200 (8 kg)		3 x SH200 (12 kg)		
Activated carbon filter(s) for organic vapors	2 x ORG200 (22 kg)		3 x ORG200 (33 kg)		
Activated carbon filter(s) for corrosive and organic vapors	2 x CORG201 (24 kg)		3 x CORG201 (36 kg)		
Activated carbon filter(s) for formaldehyde vapors	2 x FOR200 (24 kg)		3 x FOR200 (36 kg)		
Activated carbon filter(s) for ammonia vapors	2 x AMM200 (24 kg)		3 x AMM200 (36 kg)		
Additional accessories					
Containment sump + HPL work top	BB15 (13 kg)				
Containment sump + Tempered glass work top	BV15 (18 kg)				
Integrated outdoor light	2 x LUMI (1 kg)				
Tubular table on 4 feet	TR15 (65kg)				
Tubular roller table (on castors)	TA15 (61 kg)				

RANGE H**NF** X 15-211 class 2

Labopur® TABLE / TROLLEY CABINET

TABLE/TROLLEY CABINET ►

- Made of steel 15/10th; White epoxy paint RAL 9010.
- 1 adjustable shelf.
- 1 removable base trough on the bottom.
- Self closing wing doors with handles and lock.
- Large warning labels.
- 4 swivel castors (2 with locking).

Reference	Dimensions H ⁽¹⁾ x W x D (mm)	Weight (kg)
TA06	860 x 615 x 660	32
TA09	860 x 915 x 810	43
TA12	860 x 1215 x 810	54
TA15	860 x 1515 x 810	61



TA06



TR09

TUBULAR TABLE/TROLLEY ►

- Made of steel 15/10th; White epoxy paint RAL 9010.
- Available with feet or with 4 swivel castors (2 with locking).

Reference	Type	Dimensions H ⁽¹⁾ x W x D (mm)	Poids (kg)
TTF06	With feet	860 x 615 x 637	9
TTR06	With castors		10
TTF09	With feet	860 x 915 x 787	12
TTR09	With castors		13
TTF12	With feet	860 x 1215 x 787	22
TTR12	With castors		23

◀ TROLLEY

- Made of steel 15/10th
- White epoxy paint RAL 9010.
- 1 adjustable shelf (the depth of shelf is equal to $\frac{3}{4}$ of the depth of trolley).
- 4 swivel castors (2 with locking).

Reference	Dimensions H ⁽¹⁾ x W x D (mm)	Weight (kg)
TR06	860 x 615 x 637	28
TR09	860 x 915 x 787	37
TR12	860 x 1215 x 787	51
TR15	860 x 1515 x 787	65

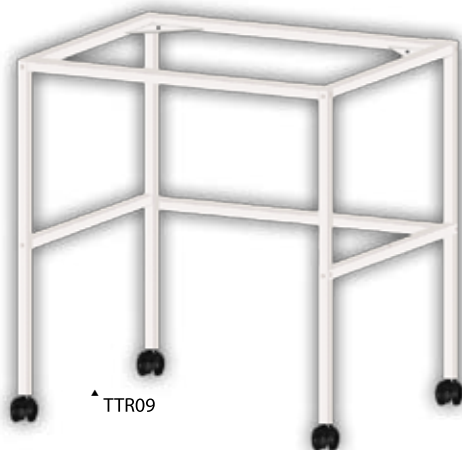

TTR09

The manufacturer reserves the right to discontinue or change specifications or designs at any time without notice and without incurring obligations. 03/2017

Flammable cabinets

Corrosive cabinets

Toxic cabinets and multirisk

Pesticide range

Fume hoods, filtering cabinets - Ventilation

Containment and Cans

Anti-fire equipments and File cabinets

Showers and first-aid equipments

⁽¹⁾Height without castors: 800 mm.

RANGE H**FUME HOODS WITH EXTERNAL CONNECTION**

* BH09D + BB09

 ^ BH15Z + BB15
 + Ventilation Box CDV-A
 + 2 KRC Connecting Kits for Box
USE

These Fume Hoods are intended to be connected to an exhausting system (1) for the discharge of toxic and harmful vapors to the outside of the building (use without activated carbon filter). It is imperative to add a ventilation box - model CDV-A (to be completed with 2 connection kits reference KRC or to be connected to an adapted exhausting system).

ADVANTAGES

- Fume Hoods delivered ready to use (no assembly), to be connected only to the electrical network and to an exhausting system.
- Transparent walls on all sides offering optimal illumination on the work top and immediate visualization of the products handled.
- Ergonomic hand traps for safe and easy handling in the enclosure.
- Lids allowing the introduction of cables for power supply of equipment and fluids inside the ductless fume hood

TECHNICAL SPECIFICATIONS

- Steel construction 15 / 10th.
- White epoxy paint RAL 9010, high resistance against chemicals.
- Glass walls made of PMMA.
- 4 caps for power cable
- Transparent rear wall

ADDITIONAL ACCESSORIES

- Ventilation Box
- Connecting Kit KRC
- Melamine work top
- Tempered glass work top
- Retention tank
- Integrated outdoor light
- Fixed and rolling tables

Ventilation and Filtration Boxes

To protect the users health and to improve the life cycle of your safety cabinet, we recommend to install an exhausting system. Do not hesitate to contact-us for more information.



Fume Hood without bottom to equip, see accessories	BH06		BH09		BH12		BH15		
External dimensions (H x W x D mm)	745 x 600 x 650		945 x 900 x 750		945 x 1200 x 750		945 x 1500 x 750		
Internal dimensions (H x W x D mm)	735 x 545 x 505		935 x 845 x 700		935 x 1145 x 700		935 x 1445 x 700		
Weight (kg)	23		34		44		54		
Hand traps type	2 hands	Trapeze	2 hands	Trapeze	2 hands	Trapeze	2 hands	Trapeze	Large Width
Reference	BH06D	BH06Z	BH09D	BH09Z	BH12D	BH12Z	BH15D	BH15Z	BH15G
Additional accessories									
Containment sump + Melamine work top	BB06 (10 kg)		BB09 (11 kg)		BB12 (12 kg)		BB15 (13 kg)		
Containment sump + Tempered glass work top	BV06 (15 kg)		BV09 (16 kg)		BV12 (17 kg)		BV15 (18 kg)		
Ventilation Box	CDV-A (8 kg)								
Connecting Kit	2 x KRC (2 kg)								

(1) Models with an external connection do not conform to NF X 15-211 - (05/2009).

RANGE H**NF X 15-211 class 2**

DUCTLESS FUME HOOD AND STORAGE CABINET WITH RECIRCULATING AIR: PMSF

Use and store your chemicals at the same place

The storage cabinet is connected to the fume hood in order to extract and purify the fumes from both items. Thus, the vapors of the cabinet and the fume hood are purified while being pulled through the active charcoal filter, then rejected into the atmosphere.

The PMSF Workstation includes :

1. A DUCTLESS FUME HOOD

Tested and approved by an independent laboratory according to the new NF X 15-211 – may 2009 – Class 2 norm

Depending on the dimensions of the fume hoods, you will find different configurations in terms of number of engines and type of hand traps.

Each reference corresponds to one specific configuration.

2. AN ACTIVE COAL FILTER

To be determined according to the chemicals handled under the hood (mandatory).

- Filter «ORG200» for organic vapors
- Multi-purpose filter «CORG201» for organic and corrosive vapors
- Filter «FOR200» for formaldehyde vapors
- Filter «AMM200» for ammonia vapors

We remind you that we can offer filters for specific applications. Please contact us for further details. There can be several filters based on the number of fan in the ductless fume hood.

(1 fan = 1 filter).



PMSF: H061Z + TA06
+ BB06 + CORG201 +
SH200 + HEP200 +
KRPMSE



PMSF: H061Z + TA06 + BB06 + CORG201 + SH200 + HEP200 + KRPMSE

3. ADDITIONAL ACCESSORIES

To add to the ductless fume hood

Mandatory: The fume hoods are bottomless, and have to be equipped with Containment sump + Melamine work top or Tempered glass work top.

The reference is determined according to the chosen fume hood and the necessary work top.

Optional: We also offer an external integrated light. Depending on the configuration chosen, there may be 1 or 2 LED lights.

4. A TABLE/TROLLEY STORAGE CABINET

- Built in steel 15/10th.
- White epoxy paint RAL 9010.
- Slef closing wing doors with handles and locks.
- Large warning labels in compliance with ISO 3864, NFX 08.003 norms and the European directive 92/58/CEE.
- 1 adjustable shelf.
- 1 removable retention tank on the bottom.
- 4 swivel castors (2 with locking).
- High and low vents (high outlet connected to the fume hood)
- KRPMSE connection kit for connecting the cabinet to the hood.

The table / cabinet reference must be chosen according to the selected hood.

Lastly, you must have a hood reference + a filter reference + one or more accessory reference (s) + a table / safety cabinet reference + the KRPMSE connecting kit.

The manufacturer reserves the right to discontinue or change specifications or designs at any time without notice and without incurring obligations. 05/2017

Flammable cabinets

Corrosive cabinets

Toxic cabinets and multirisk

Pesticide range

Fume hoods, filtering cabinets - Ventilation

Containment and Cans

Anti-fire equipments and File cabinets

Showers and first-aid equipments

LAMINAR FLOW CLEAN BENCHES, VERTICAL

INTRODUCTION

Laminar flow clean benches are designed to prevent contamination of semiconductor wafers, biological samples, or any particle sensitive device. Air is drawn through a ULPA filter and blown in a very smooth, laminar flow towards the user. Such hoods exist in both horizontal and vertical configurations. Laminar Fumehood are equipped with a germicidal UV lamp to sterilize the worplace when do not work on it. But you must switch off this light while you are working, as it will burn your skin and generate cataracts to your eyes. Nothing can be stored in the fumehood to allow the sterilization .

CONFORMITY

- Cabinet performance : EN 12469 (type-tested for cross contamination and product protection using the microbiological testing methods adapted from this biological safety cabinet standard) and IESTRP-CC002 norms.
- Air Quality: ISO 14644-1 Class 3 norm.
- Filtration: EN 1822 (H14), IEST-RP-CC001, IEST-RP-CC007 and IESTRP- CC034 norms.
- Electrical safety: IEC 61010-1 and EN 61010-1 norms.

ADVANTAGES

- ULPA filters tested to a typical efficiency of >99.999% for 0.1 to 0.3 micron particles are superior to HEPA filters.
- Stainless stell work surface with a curved front edge is designed for maximum operator comfort.
- Lighing provides excellent illumination of the work zone and reduces opeorator fatigue.
- All surfaces painted with an antimicrobial coating.

TECHNICAL DATA

- Built in galvanized steel with anti-bacteria epoxy paint.
- Work top in 304 stainless steel.
- Anti-UV tempered glass side panels.
- Control system to switch on/off light and to control the airflow.

ADDITIONAL OPTIONS - Contact-us

- Germicidal UV lamp and transparent front cover (LUH/LUV).
- Electrica outlet (PEH/PEV).
- Petcok for air, gas and vaccum (ROH/ROV).
- Tubular table with castors.- Prises électrique (PEH/PEV).



These models are also available in Horizontal Laminar flow. Contact us for more informations.

P/N		FLV900	FLV1200	FLV1500
Outside dimensions	H	1270	1270	1270
	W	1035	1340	1645
	D	784	784	784
Inside dimensions	H	678	678	678
	W	965	1270	1575
	D	739	739	739
Inside volume of enclosure (m ³)		0,6	0,8	1
Average velocity (m/s)		0,45	0,45	0,45
Nominal voltage (volts)		220-240	220-240	220-240
Power input (watts)		129	151	199
Amps absorbed (Ampères)		7,3	7,5	7,8
Sound level dB(A) (without air flow)		51,6	52,4	55,6
Flow (m ³)		1117	1471	1824
Weight (kg)		135	158	199
Fluorescent lamp intensity (Lux)		980	904	894

Standard equipments

Fluorescent lamp	included	included	included
Control system	included	included	included
ULPA filter	included	included	included

Optionnal equipments

ULPA filter replacement	ULV900	ULV1200	ULV1500
-------------------------	--------	---------	---------

Flammable cabinets

Corrosive cabinets

Toxic cabinets and multirisk

Pesticide range

Fume hoods, filtering cabinets - Ventilation

Containment and Cans

Anti-fire equipments and File cabinets

Showers and first-aid equipments



BIOLOGICAL SAFETY CABINET - CLASS 2

USE AREA

Through the manipulation of micro-organisms or products of pathogens, it should implement a protection of the operator and the environment. Ambient air is drawn directly through perforations located towards the work plan. It does not contaminate the clean room air handling. He then joined the latter contaminated air. These combined air are then returned to about 32% outward job security, to advance through a HEPA filter to protect the operator and 68% to the working chamber also passing through a HEPA filter to protect the elements manipulated. The air inflow and downflow combined and form an effective barrier preventing contaminated air from entering the working chamber but also contaminated air out of the chamber.

CONFORMITY

- Performance security post: EN 12469.
- Air Quality: ISO 14644-1 Class 3.
- Filtration: EN 1822 (H14), IEST-RP-CC034, IEST-RP-CC007 and IEST-RP-CC001 norms.
- Electrical Safety: IEC 61010-1 and EN 61010-1 norms.

ADVANTAGES

- HEPA filter with a filtration efficiency of 99.999% of particles between 0.1 and 0.3 microns by providing increased protection.
- Plan of multi-piece stainless steel work allows access to simplify the work surface to be decontaminated.
- Large opening of the protective glass improving access to the area of handling without compromising safety.
- UV absorbing tempered glass (5mm), colorless and transparent.

TECHNICAL SPECIFICATIONS

- Built in galvanized steel with antimicrobial epoxy paint.
- Worktop in stainless steel.
- Walls transparent tempered glass.
- Control panel including the speed of air flow.

ADDITIONAL OPTIONS - Contact us

- UV germicidal lamp • Electrical outlets • Faucet small diameter for water, gas or vacuum tube • Tabular table.

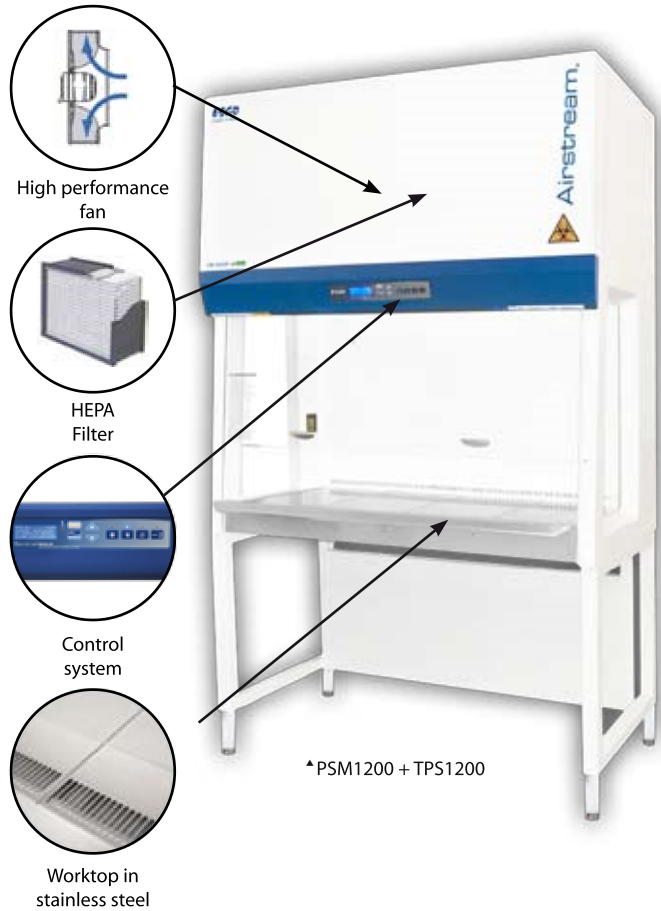

The manufacturer reserves the right to discontinue or change specifications or designs at any time without notice and without incurring obligations. 07/2015

P/N		PSM900	PSM1200	PSM1500
Outside dimension	H	1400	1400	1400
	W	1035	1340	1645
	D	753	753	753
Inside dimension	H	660	660	660
	W	915	1220	1525
	D	580	580	580
Inside volume of enclosure (m³)		0,35	0,47	0,58
Average velocity (m/s) - inflow / downflow		0,45 / 0,30	0,45 / 0,30	0,45 / 0,30
Nominal voltage (volts)		220-240	220-240	220-240
Power input (watts)		291	289	333
Amps absorbed (Ampères)		2	2	2
Sound level dB(A) (without air flow)		58	59	59
Air flow volume (m³) - Inflow / Downflow / Exhaust		270 / 563 / 270	356 / 741 / 356	440 / 916 / 440
Weight (kg)		125	150	160
Fluorescent lamp intensity (Lux)		1279	1404	1227

Standard equipments

Fluorescent lamp	included	included	included
Control system	included	included	included
HEPA filter	included	included	included

Optionnal equipments

HEPA filter replacement	ULP900	ULP1200	ULP1500
Tubular table (hauteur : 860 mm)	THF900	THF1200	THF1500

Flammable cabinets

Corrosive cabinets

Toxic cabinets and multirisk

Pesticide range

Fume hoods, filtering cabinets - Ventilation

Containment and Cans

Anti-fire equipments and File cabinets

Showers and first-aid equipments

RANGE H**NF X 15-211 Class 2**

Labopur® - MINI-DUCTLESS FUME HOOD



CONFORMITY

- Active coal filters adsorption's capacity and filtration system are tested and certified NF X 15-211 .
- Electric fans are in conformity with european specification CE.

ADVANTAGES

- Labopur's technology.
- To place on a bench or on a workbench.
- Vapours are confined in the manipulation enclosure after being eliminated through the molecular filter.
- Warning light insures a good functioning of the ventilation system.
- Front control window indicates immediately if the filter is inside and well adapted to your needs.
- High efficiency active coal filter specialized and treated following products stored in compliance with NF X 15-211.
- Dust-protecting pre-filter, efficiency 92% for particles > 3 µm.
- Easy replacement of the active coal filter.
- The standard timer supplied with your recycling air box indicates the total use of your box. After programming, every 60 hours, a sound alarm invites you to check the saturation of the active coal filter.
- Integrated base trough at the bottom to get back liquids in case of accidental droppings .
- No connecting evacuation, no civil engineering needed (if the hood is fitted with a filter).
- Our hoods are delivered ready to use (already mounted). All you have to do is plug them to a power supply device.
- Adjustable leveling feet for enhance stability.

TECHNICAL SPECIFICATIONS

- Made of steel 12/10th.
- Epoxy painting : white RAL 9010, blue RAL 5015.
- Soft and silent electrical fan: 220-240 volts - 10 watts, 0,1 A, 57 db (A) (excluding air flow) - Airflow 170 m3/hour.
- Wall sides made of PMMA, and ergonomic hand traps
- Fully opening swing front for full access inside the hood

OPTIONS

- **Active coal filter** : boxes are provided without active coal filter. You have to select one kind of filter in the boarding bellow, in as per the stored products.
- **Control of filter saturation level by REACTIVE TUBES**: Control port on the front of the box. Easy using of specialized reactive tubes. Using of manual pump for testing. Control of efficiency of the filter by reading color codes of reactive tubes.

We remind you that you can use filter for specific applications.

P/N	Description	Outside dim. H x W x D (mm)	Inside dim. H x L x P (mm)	Weight (kg)
H70	Mini-ductless fume hood (delivered without filter)	605 x 505 x 485	410 x 455 x 445	25
ORG50	Active coal filter for organic vapors	70 x 390 x 390	-	8
CORG51	Polyvalent ⁽¹⁾ active coal filter for corrosive and organic vapors	70 x 390 x 390	-	9
FOR50	Active coal filter for formaldehyde vapors	70 x 390 x 390	-	9
PMAF	Manual pump	-	-	0,4
TROR	Pack of 10 reactive tubes for organic tests	-	-	0,1
TRAC	Pack of 10 reactive tubes for corrosive tests	-	-	0,1
TROA	Pack of 5 reactive tubes for organic test and 5 reactive tubes for corrosive tests	-	-	0,1

⁽¹⁾ The latest generation «CORG» filter absorbs a large majority of chemicals commonly used in laboratories : organic and inorganic acids, solvents and organics.